



REV.	ECN NO OR DESCRIPTION	REVISED	DATE

NOTES:

1. MATERIAL:

HOUSING: High Temperature Thermoplastic
Terminal: Copper Alloy
Shell: Stainless Steel

2. PLATING:

Terminal: 50u" Ni UNDERPLATED OVERALL
G/F PLATED ON CONTACT AREA AND SOLDER AREA
Shell: 30u" Ni UNDERPLATED OVERALL
G/F PLATED ON CONTACT AREA AND SOLDER AREA

3. TECHNICAL SPECIALITY:

RATED VOLTAGE: 30V AC MAX.
CURRENT RATING: 0.5A MAX.
INSULATION RESISTANCE: 1000MΩ MIN
CONTACT RESISTANCE: 50mΩ MAX
WITHSTANDING VOLTAGE: 500V AC FOR 1 MINUTES
INSERTION FORCE: 12N MAX
PUSH-OUT FORCE: 2N MIN
OPERATING TEMPERATURE: -40°C~+85°C Humidity 80% R.H MAX

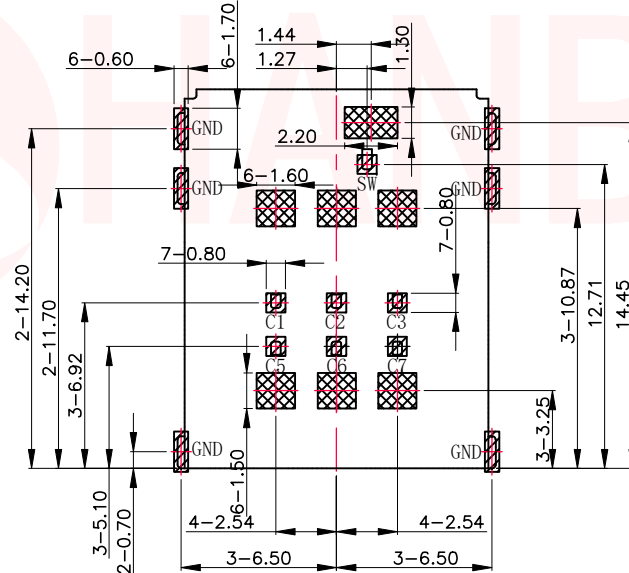
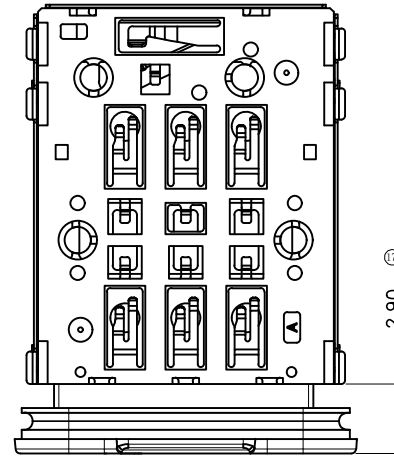
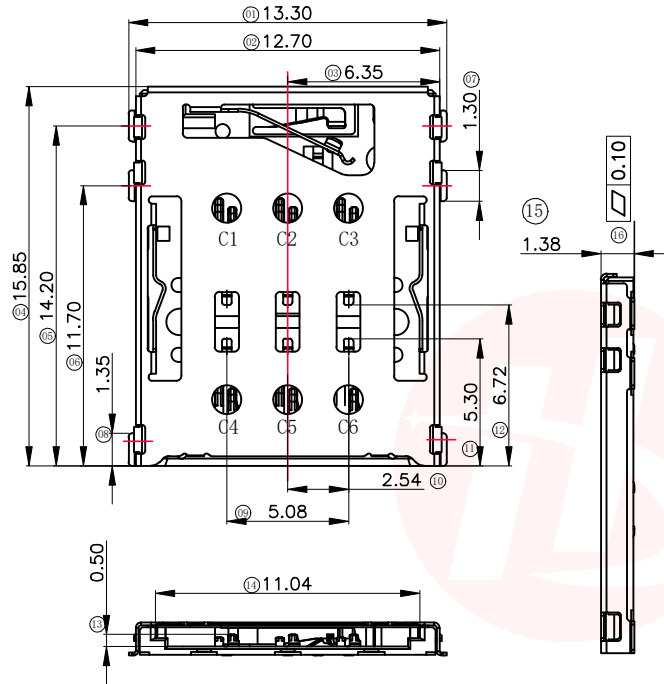

PIIN/NO	ASSIGNMENT
C1	VCC
C2	RST
C3	CLK
SW	DetectSwitch
C5	GND
C6	VPP
C7	I/O

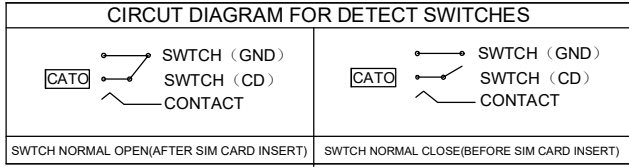

RECOMMENDED PCB LAYOUT

TOLERANCE: ± 0.05

- SMT SOLDER AREA
- COPPER RESTRICTED AREA
- 1. TOUCH AREA OF CONTACT TIPS NO ELECTRICAL FUNCTION
- 2. NO FIRST PCB_LAYOUT CIRCUITS IN THE AREA

UNLESS OTHERWISE SPECIFIED TOLERANCES

DECIMALS:	ANGLES:
X ±0.30	X ±2°
X.X ±0.20	X.X ±1°
X.XX ±0.10	

		东莞市汉博电子科技有限公司 DONGGUAN HANBO TECHNOLOGY CO., LTD	
TITLE	NANO SIM CARD 7PIN 1.38H PIN-PUSH		
DWN	xiong	PART NO. SNO-1470	
CHKD	lee	SCALE:1:1	UNIT: mm
APVD	wang	SIZE: A4	SHEET:10F 1
			REV: A4
CUSTOMER COPY			

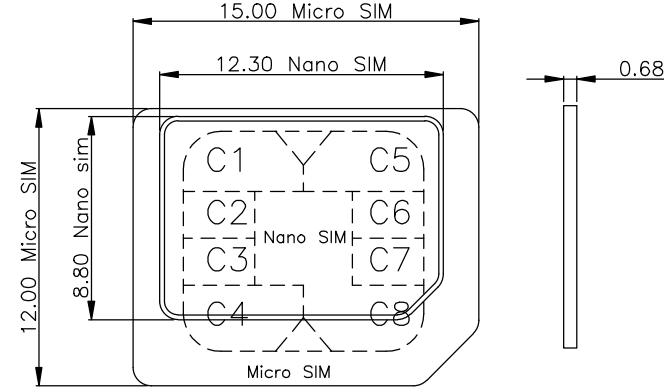



REV.	ECN NO OR DESCRIPTION	REVISED	DATE

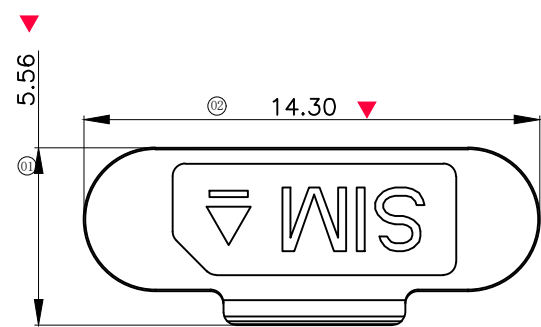

NOTES:
 1. MATERIAL:
 HOUSING: Polycarbonate Black UL94V-0
 Terminal: Copper Alloy
 Shell: Stainless Steel
 2. Product should not shrink, dirty, deformation, lack of material
 3. Products must comply with RoHS requirements

如需防水需要装配防水圈

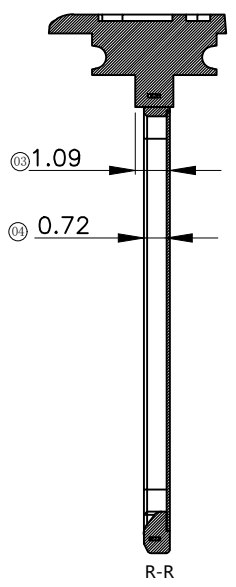
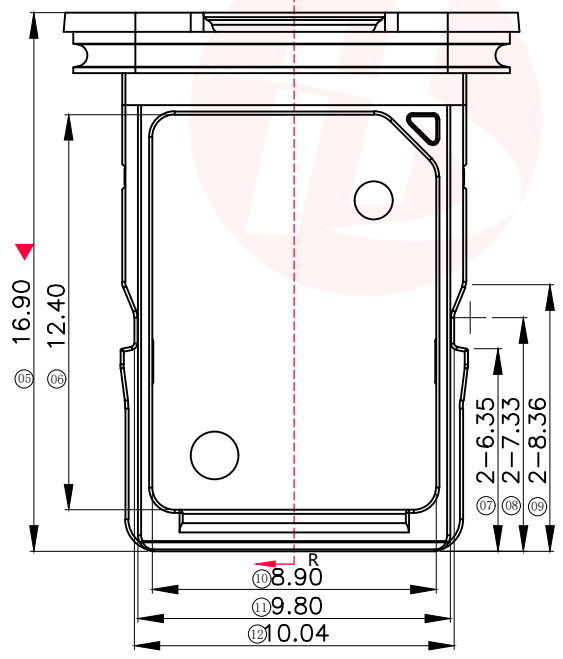
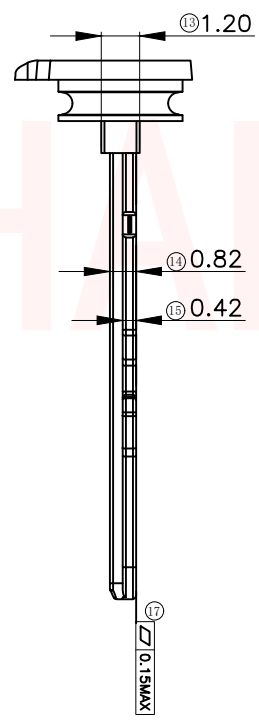
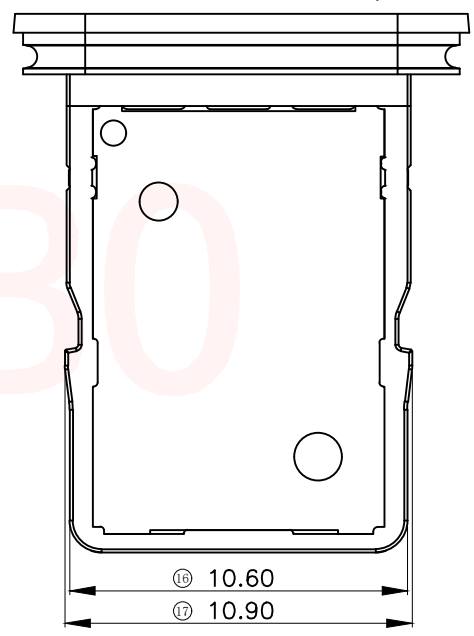

UNLESS OTHERWISE SPECIFIED TOLERANCES		东莞市汉博电子科技有限公司 DONGGUAN HANBO TECHNOLOGY CO., LTD			
DECIMALS:	ANGLES:	TITLE	NANO SIM 1.38H 防水卡托		
X : ±0.30	X : ±2°	DWN	xiong	PART NO. SNO-1470-KT-A	
X.X : ±0.20	X.X : ±1°	CHKD	lee	SCALE: 1:1	UNIT: mm
X.XX : ±0.10		APVD	wang	SIZE: A4	SHEET: 1 OF 1
CUSTOMER COPY					

A
B
C
D

A
B
C
D



REV.	ECN NO OR DESCRIPTION	REVISED	DATE

NOTES:

- MATERIAL:
HOUSING: Polycarbonate Black UL94V-0
Terminal: Copper Alloy
Shell: Stainless Steel
- Product should not shrink, dirty, deformation, lack of material
- Products must comply with RoHS requirements

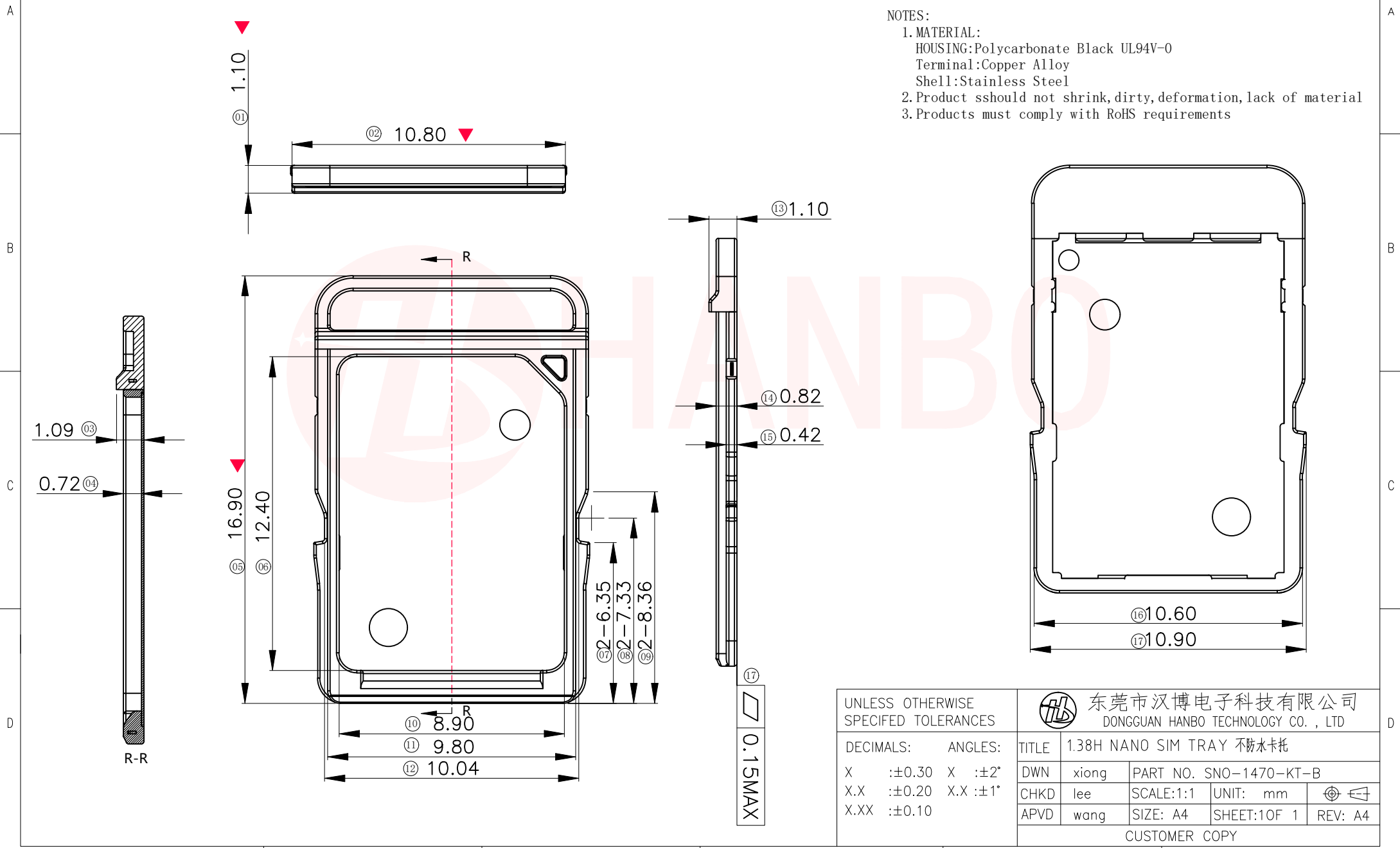

UNLESS OTHERWISE SPECIFIED TOLERANCES		东莞市汉博电子科技有限公司 DONGGUAN HANBO TECHNOLOGY CO., LTD			
DECIMALS:	ANGLES:	TITLE 1.38H NANO SIM TRAY 不防水卡托			
X : ±0.30	X : ±2°	DWN	xiong	PART NO. SNO-1470-KT-B	
X.X : ±0.20	X.X : ±1°	CHKD	lee	SCALE: 1:1	UNIT: mm
X.XX : ±0.10		APVD	wang	SIZE: A4	SHEET: 10F 1
CUSTOMER COPY					



REV.	ECN NO OR DESCRIPTION	REVISED	DATE

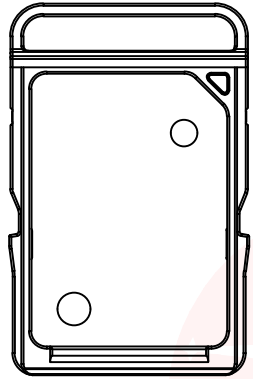

PRODUCT

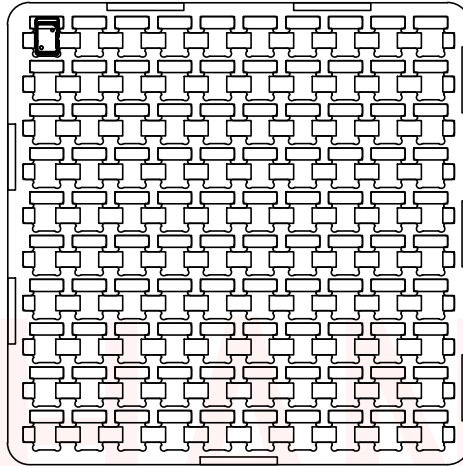

TRAY

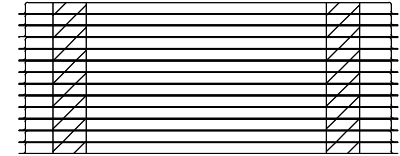
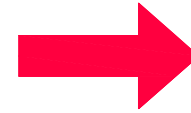

PE Bag

51PCS/Box
An empty plate on top

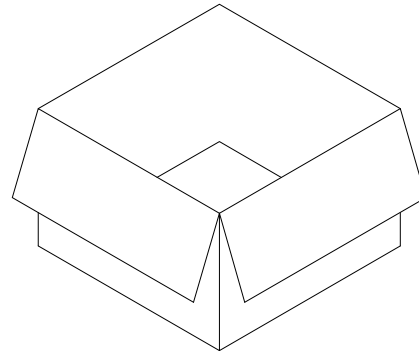

BOX

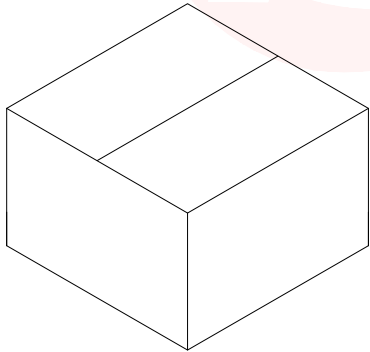
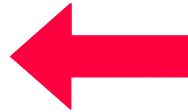

料号	品名规格	数量
	Clapboard (Material B=B T=7 210*210)	2PCS
	Box (K=K,T=7.0,240*240*215)	1PCS
	PE Bag (T=0.08mm, 400*500, Opening400)	1PCS
	Blister plate (100PCS/Plate)	51PCS
SNO-1470-KT-B	Product	4000PCS

UNLESS OTHERWISE SPECIFIED TOLERANCES

DECIMALS: ANGLES:
 X :±0.30 X :±2°
 X.X :±0.20 X.X :±1°
 X.XX :±0.10



东莞市汉博电子科技有限公司
DONGGUAN HANBO TECHNOLOGY CO., LTD

TITLE	1.38H NANO SIM TRAY 包装示意图			
DWN	xiong	PART NO. SNO-1470-KT-B		
CHKD	lee	SCALE:1:1	UNIT: mm	④
APVD	wang	SIZE: A4	SHEET:10F 1	REV: A4
CUSTOMER COPY				