

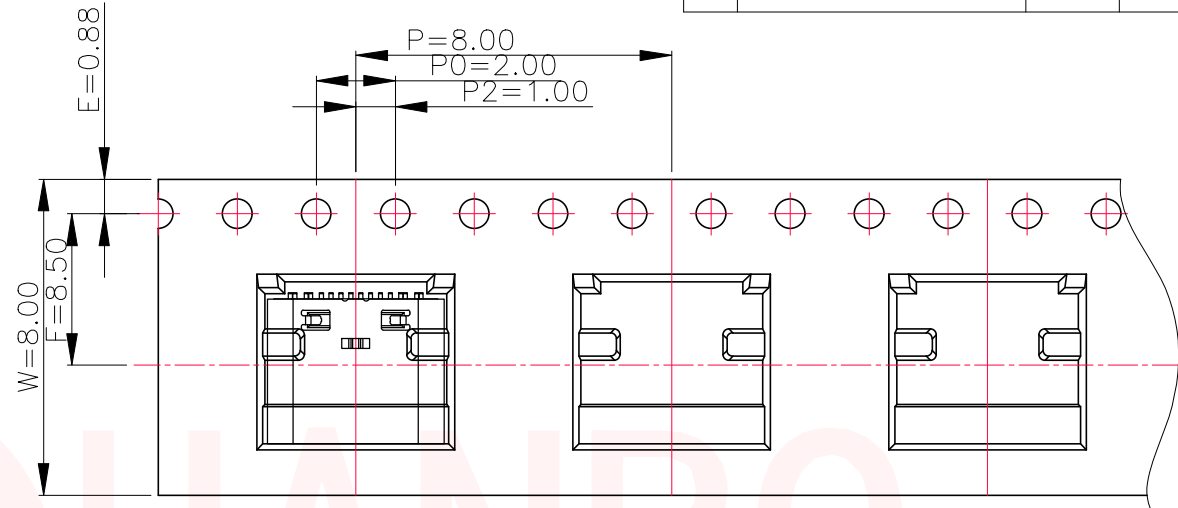

REV.	ECN NO OR DESCRIPTION	REVISED	DATE

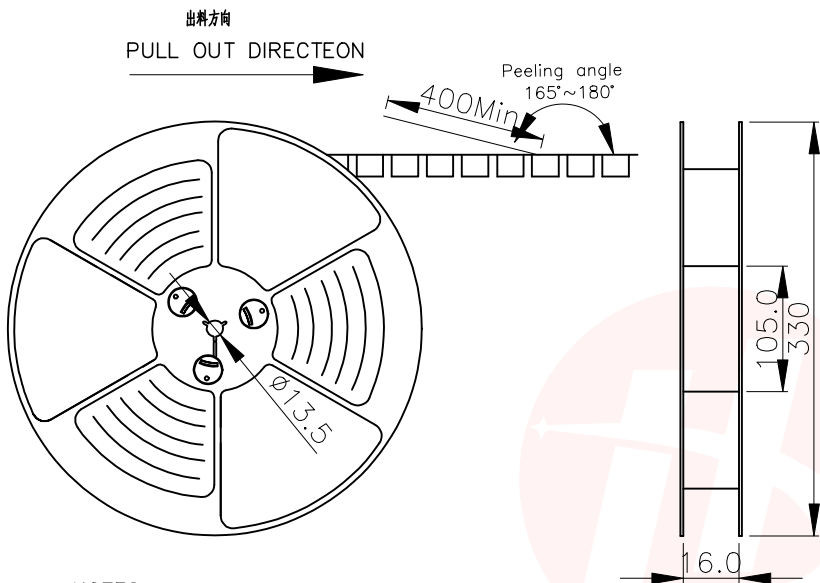

NOTES

1. 帶子引導長度
LEAD TAPE LENGTH

出料方向 PULL OUT DIRECTEON
出料方向 PULL OUT DIRECTEON

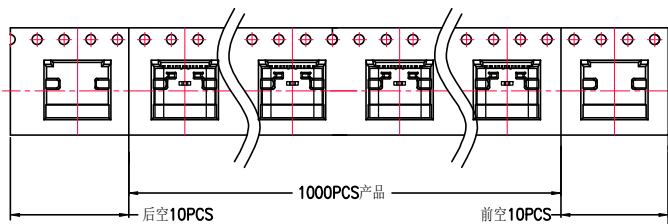

2. 上帶 剝力力為: 0.1~1.3N(10.2gf~130gf)
PEELING OFF FORCE OF TOP TAPE: 0.1~1.3N(10.2gf~130gf)

出貨運輸過程中一定注意:

THIS REQUIREMENT SHOULD BE APPLIED AT SHIPMENT:

卷帶在運輸過程中不能散開

PEELING OFF SHOULD NOT BE ALLOWED DURING TRANSPORTATION

TAPE & REEL 14 PCS

1 REEL
= 1000 PCS

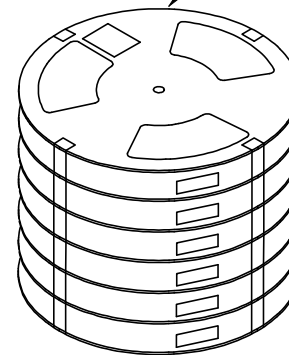

BOX

DIMENSIONS:
33.5X33.5X30.5

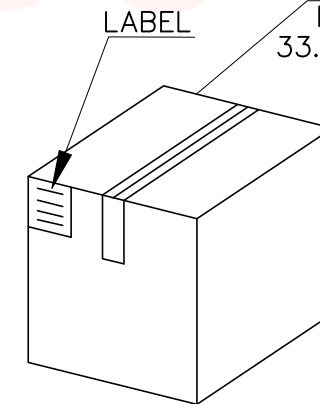

1 CARTON
= 14 REELS
= 14000 PCS

UNLESS OTHERWISE SPECIFIED TOLERANCES

DECIMALS:	ANGLES:
X :±0.30	X :±2°
X.X :±0.20	X.X :±1°
X.XX :±0.10	



东莞市汉博电子科技有限公司
DONGGUAN HANBO TECHNOLOGY CO., LTD

TITLE	USB TYPE C 16P 四脚DIP L=7.35 垫高1.0			
DWN	xiong	PART NO.	MC-126D-DG10	
CHKD	lee	SCALE:1:1	UNIT: mm	
APVD	wang	SIZE: A4	SHEET:1OF 1	REV: A4

CUSTOMER COPY