

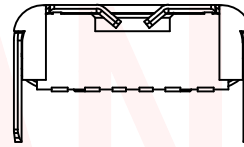

REV.	ECN NO OR DESCRIPTION	REVISED	DATE

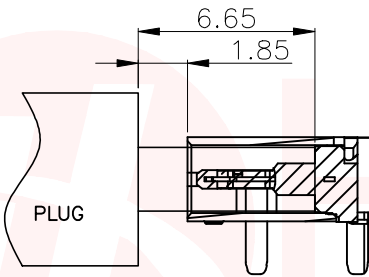

AFTER MATING

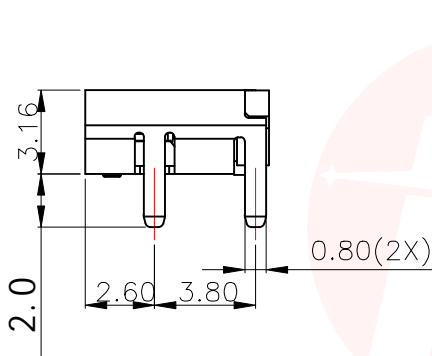
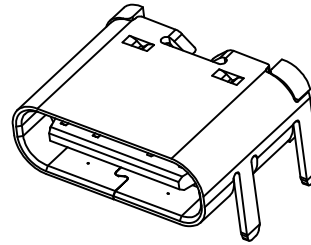
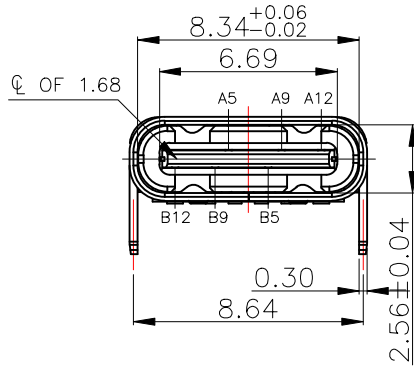
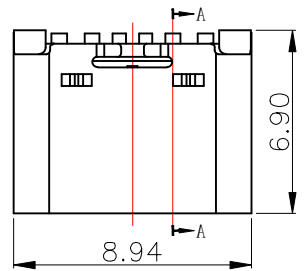
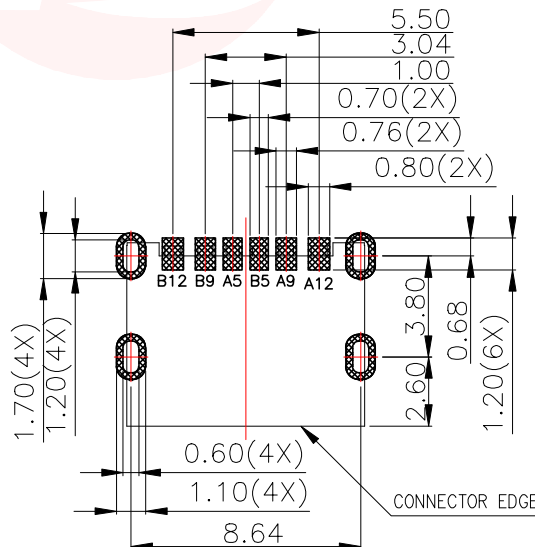
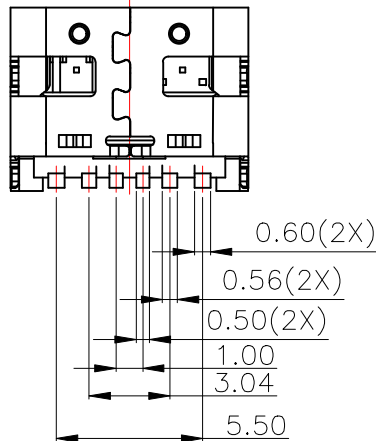

RECOMMENDED PCB LAYOUT (TOP VIEW)
DEFAULT TOLERANCE: ±0.05

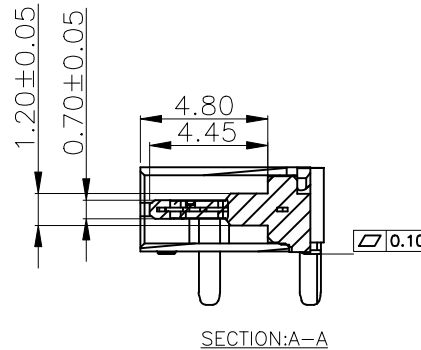

- NOTE:
- MATERIAL SPECIFICATION:
 - HOUSING: HIGH TEMPERATURE RESISTANT PLASTIC, UL94 V-0.
 - TERMINAL: COPPER ALLOY
 - MID PLATE: STAINLESS STEEL
 - FRONT SHELL: STAINLESS STEEL
 - PLATING SPECIFICATION:
 - TERMINAL:
 - Ni 50u" MIN. UNDER PLATED OVER ALL.
 - Au PLATED ON THE FUNCTIONAL AREA OF CONTACT. (GOLD PLATING THICKNESS FOLLOW THE P/N)
 - PLATING SPECIFICATIONS OF THE SOLDER AREA FOLLOW THE P/N
 - FRONT SHELL:
 - PLATING SPECIFICATIONS FOLLOW THE P/N
 - MID PLATE:
 - CLEAR ONLY
 - MECHANICAL PERFORMANCE,
 - INSERTION FORCE: 0.5~2.0kgf.
 - REMOVAL FORCE: 0.8kgf~2.0kgf.
 - DURABILITY: 10000 CYCLES.
 - ELECTRICAL PERFORMANCE,
 - VOLTAGE RATING: 5 V DC/AC (RMS. max)
CURRENT RATING: SEE P/N;
1.5AMPS MIN FOR VBUS PIN,
0.25 AMPS. FOR ALL OTHER CONTACT.
 - LLCR:
 - VBUS & GND PINS AND OTHER PINS: 40mA/PIN MAX.
SHIELD: 50mA/MAX.
LLCR MAX. CHANGE OF ALL PINS: 10mA.
 - INSULATION RESISTANCE: 100MΩ MIN
 - DIELECTRIC WITHSTAND VOLTAGE, AC 100V FOR 1 MINUTE.
 - ENVIRONMENTAL PERFORMANCE:
 - OPERATING TEMPERATURE: -25°C~+85°C.
 - IR REFLOW:
 - THE PEAK TEMPERATURE ON THE BOARD SHALL BE MAINTAINED FOR 10 SECONDS AT 260°C.

PIN ASSIGNMENTS

A5	CC1	B12	GND
A9	VBUS	B9	VBUS
A12	GND	B5	CC2
PIN	SIGNAL NAME	PIN	SIGNAL NAME

UNLESS OTHERWISE SPECIFIED TOLERANCES

DECIMALS:	ANGLES:
X : ±0.30	X : ±2°
X.X : ±0.20	X.X : ±1°
X.XX : ±0.10	



东莞市汉博电子科技有限公司
DONGGUAN HANBO TECHNOLOGY CO., LTD

TITLE	USB CF TYPEC 6PIN 板上6.90 脚长2.0 SMT CONN			
DWN	xiong	PART NO. MC-301D-H20		
CHKD	lee	SCALE: 1:1	UNIT: mm	
APVD	wang	SIZE: A4	SHEET: 10F 1	REV: A4
CUSTOMER COPY				



REV.	ECN NO OR DESCRIPTION	REVISED	DATE

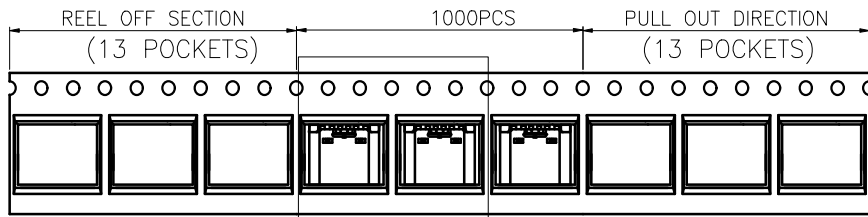

SEE DETAIL X

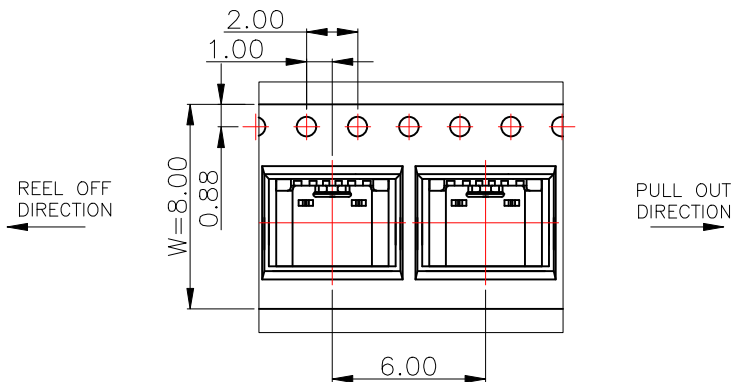
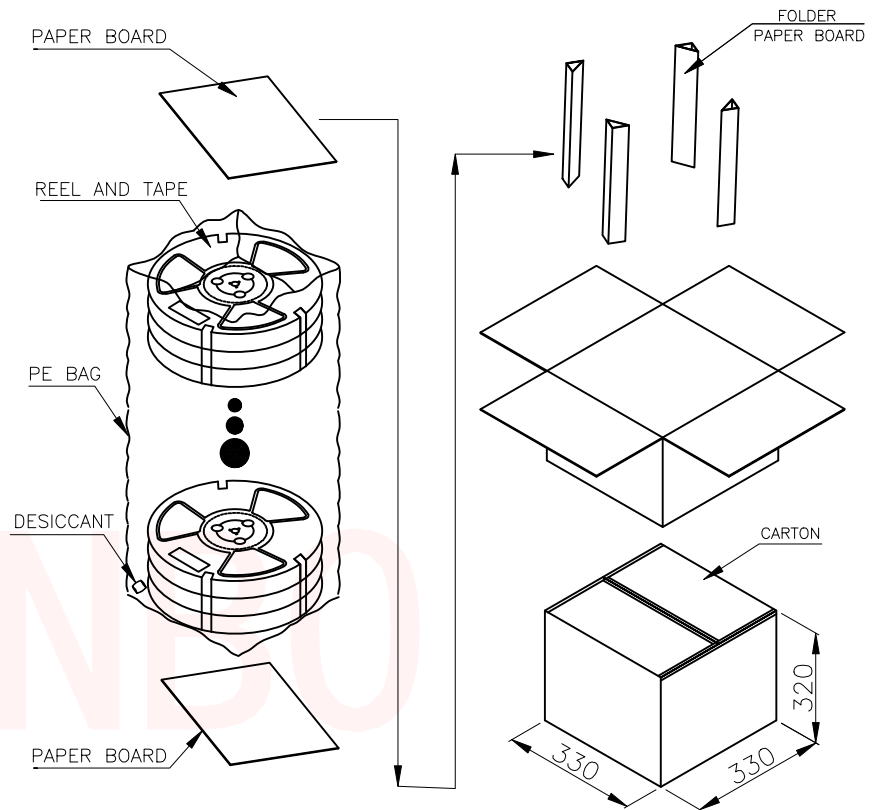
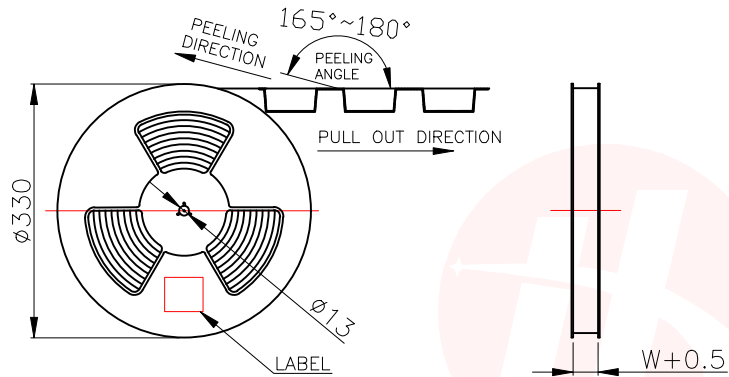

	REEL	CARTON
CONNECTOR (PCS)	1000	14000
UNLESS OTHERWISE SPECIFIED TOLERANCES	东莞市汉博电子科技有限公司 DONGGUAN HANBO TECHNOLOGY CO., LTD	
DECIMALS:	TITLE	
X :±0.30	DWN xiong PART NO. TS-KG58S-AT35F	
X.X :±0.20	CHKD lee	SCALE:1:1 UNIT: mm
X.XX :±0.10	APVD wang	SIZE: A4 SHEET:10F 1 REV: A4
CUSTOMER COPY		