

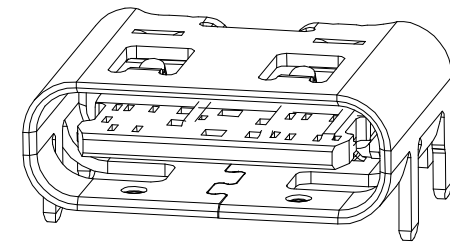

REV.	ECN NO OR DESCRIPTION	REVISED	DATE

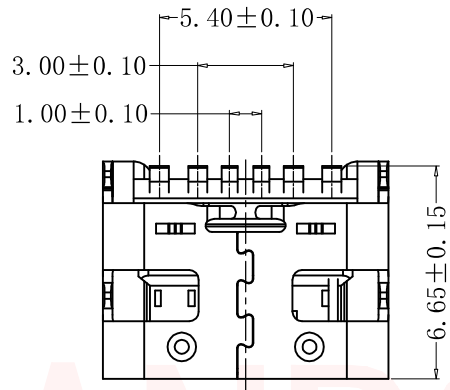
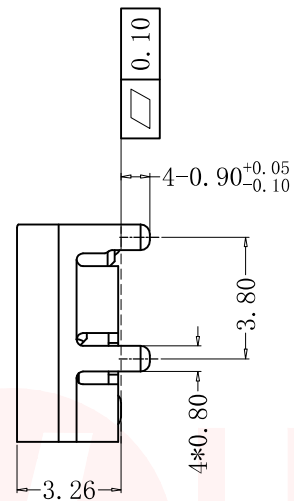
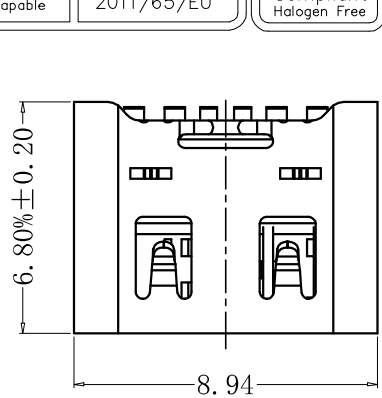

**SPECIFICATION:**

- Material & Finish: See the list;
- Mechanical:
  - Mating force: 5-20Nf;
  - Unmating force: 6-20Nf;
  - Durability: 3000 Cycles;
- Electrical:
  - Current Rating: 3A Max.;
  - Voltage Rating: 20V Max.;
  - Dielectric Withstanding voltage: 100Vac;
  - Contact resistance: 40m Ohms Max.;
  - Insulation Resistance: 100M Ohms Min.;
- Environmental:
  - Operating temperature: -40° C ~ +85° C;
  - Salt Spray Test: 24H Min. (No oxidation or rust);
  - Wetting Temperature: 265 ± 5° C, 5 ± 0.5s

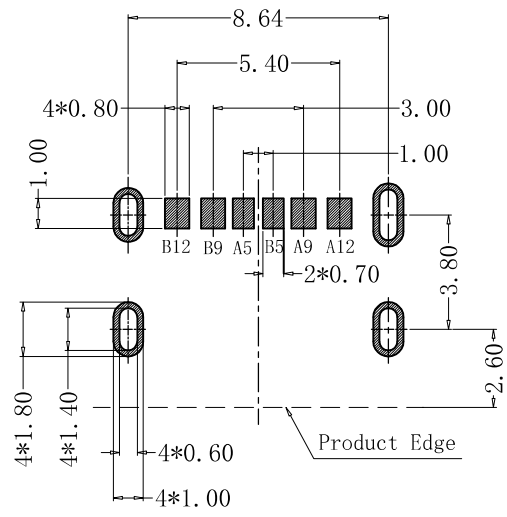
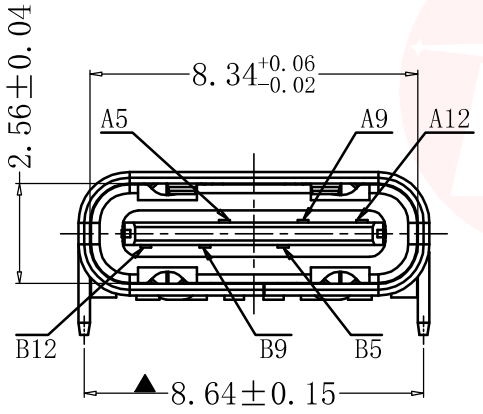

RECOMMENDED P.C.B. LAYOUT  
TOLERANCE UNSPECIFIED ±0.05mm

A5	CC1	B5	CC2
A9	VBUS	B9	VBUS
A12	GND	B12	GND
PIN	SIGNAL	PIN	SIGNAL

PN.	DESCRIPTION			
MC-301DM	塑胶LCP黑色, 外壳SUS201脚长0.90, 端子C5191接触区镀金1u", 焊脚镀金G/F			
NO.	PART NAME	Q' TY	MATERIAL	FINISH
3	Shell	1	SUS201 T=0.30mm	Ni
2	Housing	1	LCP	UL 94 V-0
1	Contact	1	C5191 T=0.20mm	Au

UNLESS OTHERWISE SPECIFIED TOLERANCES

DECIMALS: X :±0.30 X.X :±0.20 X.XX :±0.10

ANGLES: X :±2° X.X :±1°

**东莞市汉博电子科技有限公司**  
DONGGUAN HANBO TECHNOLOGY CO., LTD

TITLE: TYPE C 6PIN板上 全包 L=6.80 带双压

DWN	xiong	PART NO.	MC-301DM
CHKD	lee	SCALE: 1:1	UNIT: mm
APVD	wang	SIZE: A4	SHEET: 10F 1

CUSTOMER COPY



REV.	ECN NO OR DESCRIPTION	REVISED	DATE

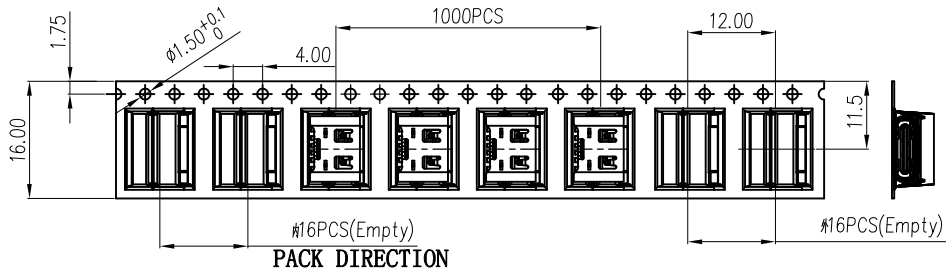

说明:

1. 每卷前后各空16PCS, 尾部用美纹胶纸封住;
2. 将产品放满盘后, 再卷一圈保护带, 用美纹胶纸将其封住, 并贴上1Pcs物料标签;
3. 每15卷盘一叠共15000Pcs装入1个外箱内;
4. 在搬运过程中要轻拿轻放;
5. 在运输中不可堆放过多(1.8M最高), 不可重压;
6. 跌落测试条件:  
成品箱从1.2米高度自由落体(一角三棱六面):  
a. 产品不可跑出下带凹槽;  
b. 产品不可有摔伤, 变形;  
c. 内包装材料不可严重破损.

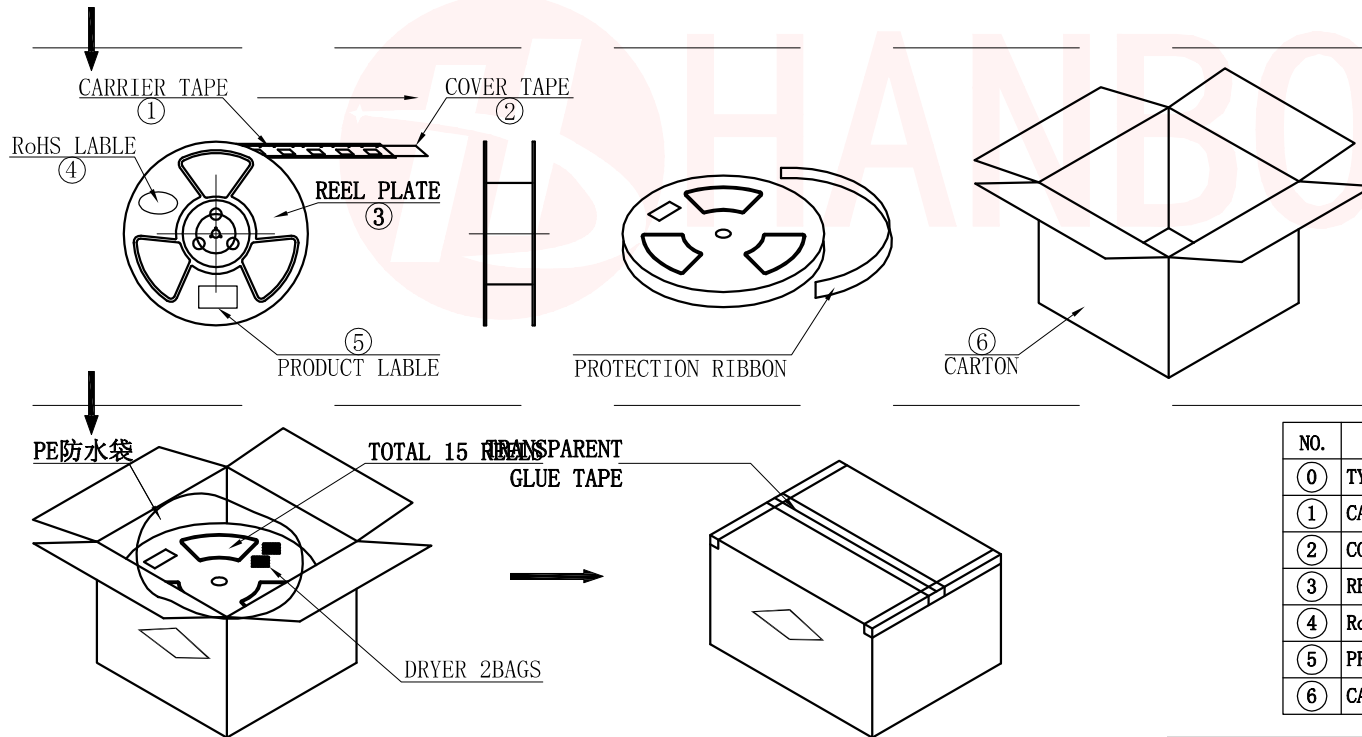

NO.	NAME	SPEC	Q' TY
0	TYPE C RECEPTACLE		15000PCS/CARTON
1	CARRIER TAPE	W=16mm, T=0.40mm	1000PCS/PLATE
2	COVER TAPE	W=13.2mm	15PLATES/CARTON
3	REEL PLATE	ø330*100*16.4mm	15PCS/CARTON
4	RoHS LABEL		15PCS/CARTON
5	PRODUCT LABELER		15PCS/CARTON
6	CARTON	340*340*325mm	1PCS/PACKAGE

UNLESS OTHERWISE SPECIFIED TOLERANCES

DECIMALS: ANGLES:  
X :±0.30 X :±2°  
X.X :±0.20 X.X :±1°  
X.XX :±0.10



东莞市汉博电子科技有限公司  
DONGGUAN HANBO TECHNOLOGY CO., LTD

TITLE	TYPE C 6PIN板上 全包 L=6.80 带双压			
DWN	xiong	PART NO. MC-301DM		
CHKD	lee	SCALE:1:1	UNIT: mm	
APVD	wang	SIZE: A4	SHEET:10F 1	REV: A4

CUSTOMER COPY